

Hallett®

UV
PURE®

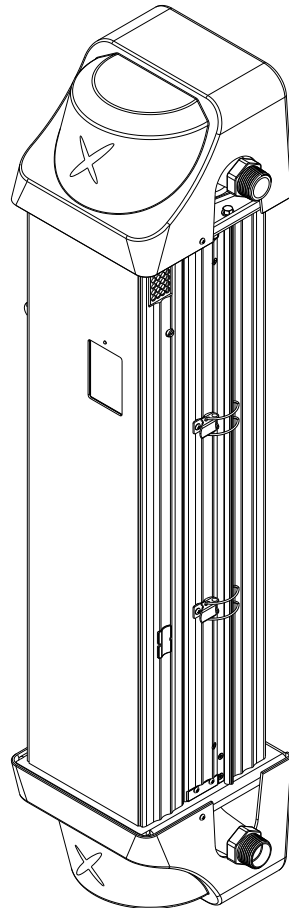

Powered by

CROSS  **FIRE**® TECHNOLOGY



Hallett 500PN & 750PN are
NSF/ANSI 55 CLASS A
CERTIFIED by NSF



NSF/ANSI 61 Section 8 for
material safety only and NSF/ANSI
372. Not certified by WQA for
contaminant reductions or
structural integrity.



LR1382

Introducing Hallett Low Alarming Validated UV Comply with the Acceptable Solutions with ease

Lamp and
Sensor in air

In-built
data logging

CROSS X FIRE TECHNOLOGY

Touch screen
user interface

**Self
Cleaning
Mechanism**

10 x more
tolerant
of mineral
contamination

**Fridge
Door
Design**



CERTIFICATIONS



UVDGM
United States
Environmental Protection
Agency

Class A
NSF 55
Certified





1000P

500PN & 750PN

Hallett™ Validated UV & Specifications

Product Line	Hallett™ P 		
Applications	Potable		
Hallett Models	1000, 750, 500, 750PN, 500PN		
Certifications & Validations	NSF/ANSI 61 - 372 - all models, except 400 model		
	NSF/ANSI 55 Class A (PN models only)		
	EPA UVDGM validated – 1000 model only		

Also Available:

Product Line	Hallett™ W 	Hallett™ R 	Hallett™ NC 
Applications	Wastewater	Reuse & Rainwater	Any (formerly Upstream)
Hallett Models	1000, 750, 500	1000, 750, 500	1000, 750, 500, 400
Certifications & Validations	NSF/ANSI 61 - 372 - all models, except 400 model		
	EPA wastewater validated (1000 model only)	NWRI reuse validated (1000 model only)	Third-party performance validated
	EPA UVDGM validated – 1000 model only 		1000NC not EPA validated

Operating Pressure ¹	34-690 kPa
Water Temperature Range ²	1-40° C ⁵
Air Temperature Range ²	1-40° C)
Maximum Relative Humidity ³	70%
Voltage Input	Check
Manifold materials	316 Stainless Steel
External Contact	2 available - Standard
Remote Start/Stop	Standard
Data Logging to USB Drive	Optional on all units
Automatic Solenoid Shutoff Valve	Optional on all units
Wetted Parts ⁴	Meets NSF/ANSI 61 & NSF/ANSI 372

¹ Purging requires pressure to work properly. The optional shutoff valve requires min 10 psig to operate

² An optional UV lamp heating kit is available for LPHO lamp systems to allow continuous operation in low water and air temperatures.

³ For continuous flow potable applications, it is recommended to dehumidify the room where the UV unit is located

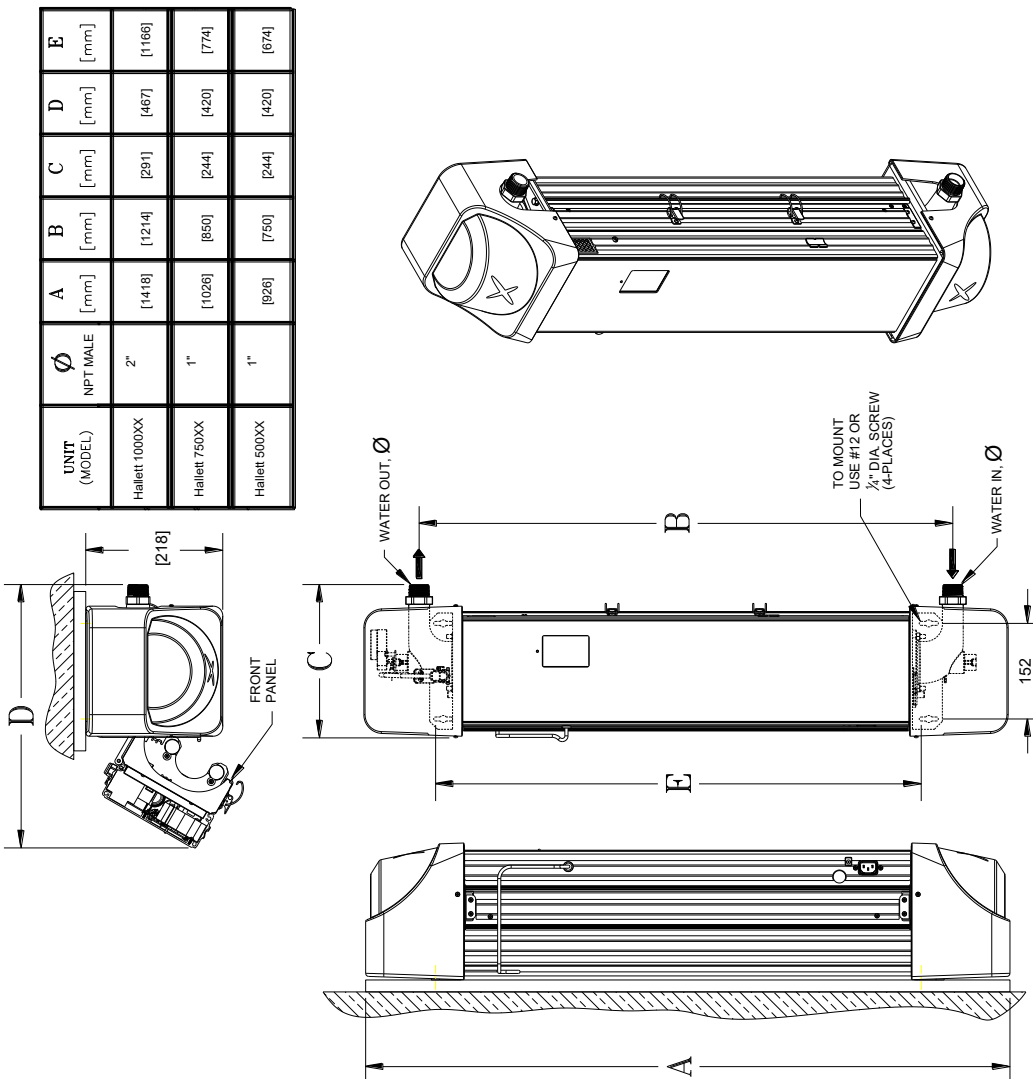

Potable Water

Hallett Models	Hallett 1000P	Hallett 750PN	Hallett 500PN
Max. Flow Rate ¹	378 L/min 22.7 m ³ /hr	104 L/min 6.2 m ³ /hr	62 L/min 3.8 m ³ /hr
Performance Certifications ²	USEPA UVDGM 2006	NSF/ANSI 55 Class A	NSF/ANSI 55 Class A
Min. UVT ³	95%	80%	75%
Flow Restrictor	No	Yes	Yes
Pressure Drop	4.4 psig (30 kPa)	22.7 psig ⁴ (156 kPa)	22.7 psig ⁴ (156 kPa)
Lamp Type	Amalgam	LPHO	LPHO
Lamp Life ⁵	16 months	12 months	12 months
Cycles/day ⁶	6-12	2	2
UV Sensor	Quad	Dual	Dual
Built-in Purge Valve	Standard	Standard	Standard
Automatic Quartz Sleeve Cleaning Device	Standard	Standard	Standard
Wiper Position Switch	Standard	Standard	Standard
Lamp Heaters	No	Standard	Standard
4-20mA Output	Optional	Optional	Optional
Modbus connectivity	Optional	Optional	Optional
Power Draw	403W	222W	196W
Inlet & Outlet Port size	2" MNPT	1" MNPT	1" MNPT
Nominal Dimensions (L x W x D)	(142x29x 22cm)	(103x24x 22cm)	(93x24x 22cm)

¹ Based on UV Dose of 40mJ/cm² at alarm setpoint.

² NSF/ANSI 55 Class A certifications substantiated by NSF International only. Third party validations are pending.

³ The Hallett 1000P can operate over a wide range of UVTs with the UV dose EPA validated between 16-200mJ/cm². Consult UV Pure to correctly configure the unit. The Hallett 750P and 500P can be configured to high or low UVT applications by service technicians.

⁴ The flow restrictor adds significant pressure drop so the value presented is at 75% of maximum flow capacity.

⁵ Amalgam lamp lifetime is 12,000hrs/500 days and LPHO lifetime is 9000hrs/375 days

⁶ Exceeding the recommended daily cycles will accelerate the age of the UV lamps. LPHO lamps perform more reliably when operated 24/7.

Water Parameters for Treating Potable Water:

The minimum water requirements are:

- **UV Transmittance (UVT)** – see Product Specification Tables. It is recommended for the water to be tested for UV transmittance in any applications using cisterns, surface water or ground water under the influence of surface water.
- **Total Dissolved solids (TDS)** - must be less than or equal to 1000 mg/L (mg/L=ppm)
- **Level of turbidity** - or cloudiness - of less than or equal to 1 NTU (nephelometric turbidity unit). In a point of entry application, a 5 micron sediment filter is recommended before the unit to reduce turbidity (the presence of a filter will also simplify disinfection of plumbing – see *Disinfecting the Plumbing* section). For surface waters, a dual gradient pre-filter (75x25 or 50x5) is recommended.

Parts Included

- UV system complete with integral wall brackets (1)
- Ultraviolet lamps (2) – installed within the unit
- Instruction manual (1)
- Power cord (1) (located within packaging)
- 20 feet of flexible hose to connect purge valve to drain (if applicable)
- Flow Restrictor (only for NSF/ANSI 55 Class A units, optional for other units)

- Optional**
- Automatic shutoff solenoid valve
 - Stainless flexible hoses (useful for installation & maintenance)
 - Pre-treatment sediment and or carbon filter designed to remove water particles, odor or trace chemicals for improved taste.
 - Strain Relief Kit for external wiring # GD21

Other Materials Needed

The UV Pure unit requires four #12 to 1/4" diameter fasteners (not provided) to mount to a wall. Pipe insulation is recommended for any overhead piping to prevent condensation from dripping onto unit. The unit also requires a drain for the purge valve discharge line.

The optional solenoid valve ensures that should the system fail, due to power loss, low UVT or low UV lamp output, the system will fail in safe mode and shut down the water flow. It is recommended install the solenoid valve just after the UV unit provided that a flood detection device exists at the site – this allows the unit to purge during alarm situations. If a flood detection device is not present, install the solenoid valve ahead of the UV unit. The direction of flow through the solenoid valve is important – verify flow direction with label on the valve. Water will not flow backwards through the valve. Keep the coil of the valve pointing upward (to prevent water from dripping on it). The valve requires minimum 69kPa (10psig) to fully open.

The optional solenoid valve is normally closed and must be powered to open. Some of the solenoid valves offered have a manual override (white lever) that

can be used to force the valve open. In any regulated sites such as municipal applications, the manual override should not be used. For normal operation, always leave valve in automatic position. In the *Advanced Settings* menu, item 2.7.3, toggle the valve to be “Installed” and a monthly reminder will appear to test valve. Please test valve monthly.

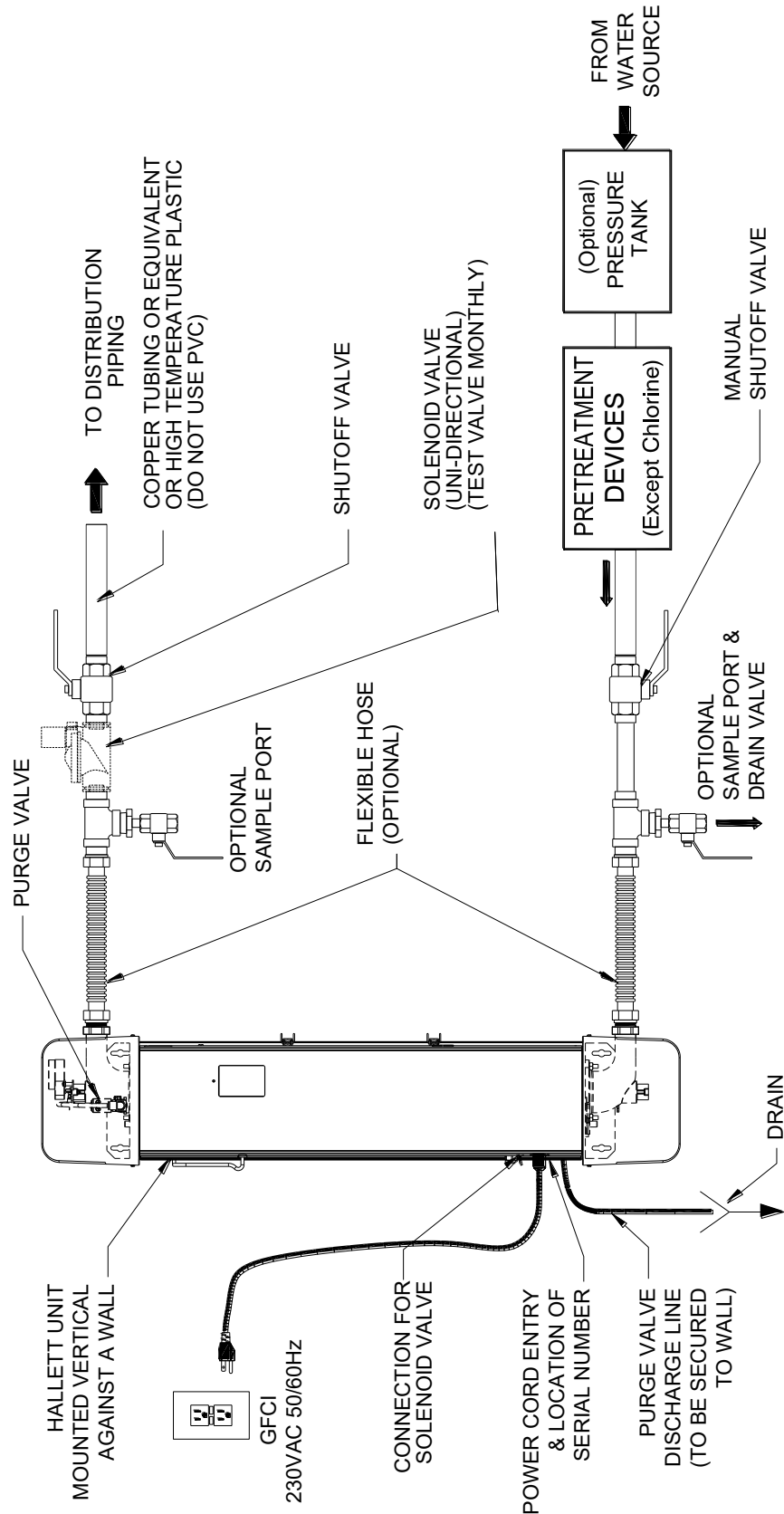

Step 3: Connect the purge valve to a drain using the tubing provided – see Figure 4.3. The tubing can be placed down the back side of the unit. The tubing should be secured to the wall or floor to prevent it from moving during the purging cycle. **During startup of the unit, it is strongly recommended to test the purge valve to confirm connections are free of leaks and the water discharges to drain.**



Step 4: Caution: do not allow the inside of the unit to get wet. Before opening the water supply, double check all connections and taps. Slowly turn on the water supply, vent out trapped air and check for leaks. If leaks exist, investigate the cause and repair before plugging in the unit.

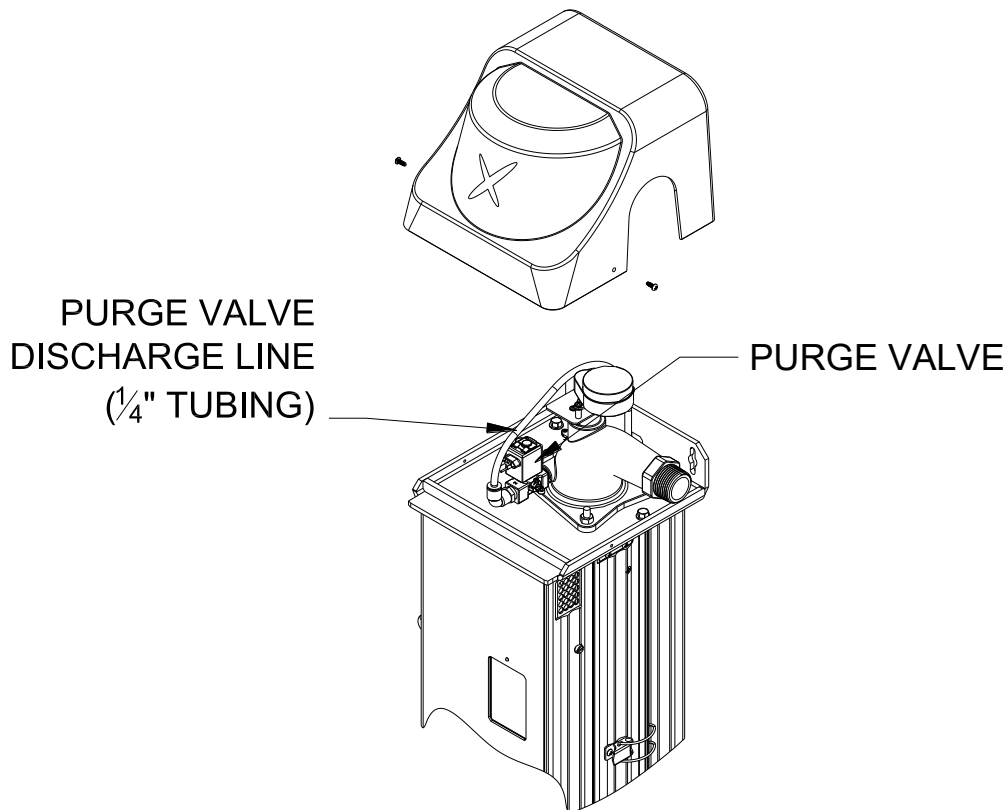

Figure 4.3

Step 5: Once the system is checked for leaks under full system pressure, install pipe insulation to any overhead piping to prevent condensation from falling onto or into the unit.

Important: after the unit has been operating for a few hours, check all connections for leaks (specifically at flexible hoses if purchased). **Repeat this procedure periodically.**

Parallel Installation

When more than one unit is installed in parallel (flow split between units), the units must be installed with manual shutoff valves both upstream and

downstream of each unit. This allows one unit to be serviced without interrupting the flow to the other units. Another requirement is the installation of a check valve downstream of the UV unit (after the UV unit). This will prevent the backflow of water to a unit.

Installation is now complete.

Control Interfaces



WARNING: Shutdown and unplug the unit before installing any external wiring.

External wiring can be introduced through a port in the left side of the unit – see Figure 4.4. By default, a plug is installed into this port in a standard unit and a strain relief (Kit # GD21) can be purchased if connection to remote devices is required. For External Contacts and Remote Start/Stop, 22 gauge wire is recommended and if the 4-20mA option is used, 22 gauge wire with foil and drain wire. Install wires onto spring cage terminals provided.

External Contacts

All Hallett systems provide two “dry” contacts for remote alarms or autodialers – the word “dry” indicates no voltage present at the contact. The first contact labeled RUN is a “System Run” condition – when closed, the unit is treating; if the contact is open, the unit is in alarm, has lost power, or perhaps the wire has been cut. The second contact labeled WARNING is to indicate the existence of an abnormal condition such as high water temperature. When this contact is open, the system is normal; when this contact is closed, a warning condition exists. Both contacts are meant for control purposes only, not to drive devices. The maximum rating of the contact is 24 Vac or Vdc, 2A.

Remote Start/Stop

All Hallett systems have remote start/stop capability which allows them to remain idle without operating the UV lamps. When a signal is given (voltage applied), UV lamps are energized. This is convenient for locations requiring periodic disinfection such as pump houses. The voltage rating range of the contact is 5-24 Vdc or Vac, 0.5W max. The remote start/stop is disabled by default and can be enabled in the Advanced Settings menu.

4-20mA & Modbus Option

A 4-20mA option is available on certain models. This device will provide a continuous analog output signal for UV Intensity and UV Transmittance. Modbus capability will also be available when the 4-20mA option is purchased. For more details, refer to the 4-20mA Instruction Sheets which are supplemental to this manual.

Data Logging on USB Option

Data logging capability is an available option on all Hallett units. A small USB drive is used to record system performance every 30 seconds. The USB drive has the capacity to store up to 4 years' worth of daily records. For more details, refer to the Data Logging Instruction Sheets which are supplemental to this manual.

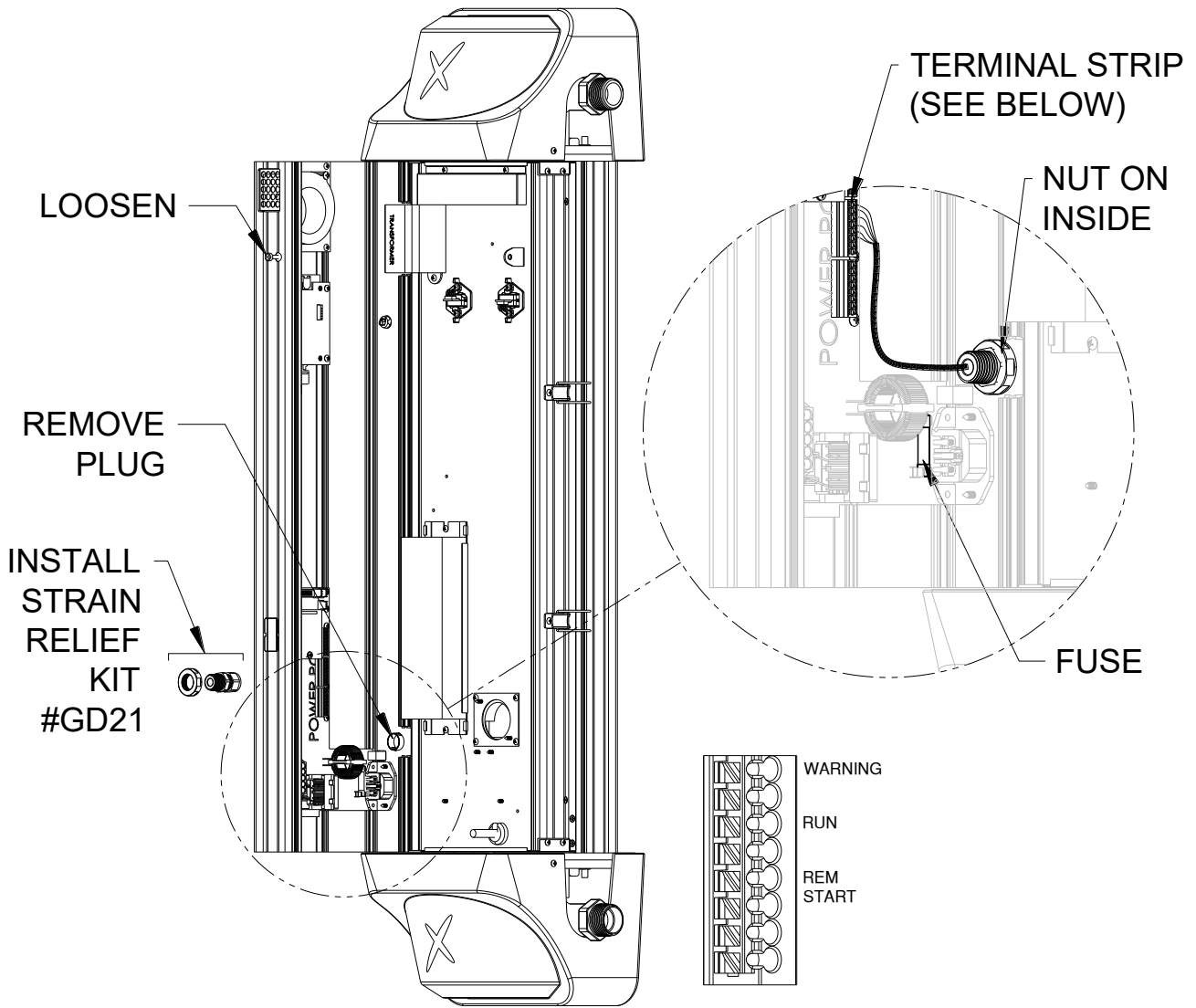

Figure 4.4

5. OPERATING INSTRUCTIONS

The Hallett applies advanced Crossfire Technology yet is simple to operate. The automatic quartz sleeve cleaning technology available on most models has been designed to reduce, and in most cases, eliminate the periodic shutdowns necessary to inspect the cleanliness of the quartz sleeve. The only required maintenance is the replacement of the two UV lamps.

Unit Functions

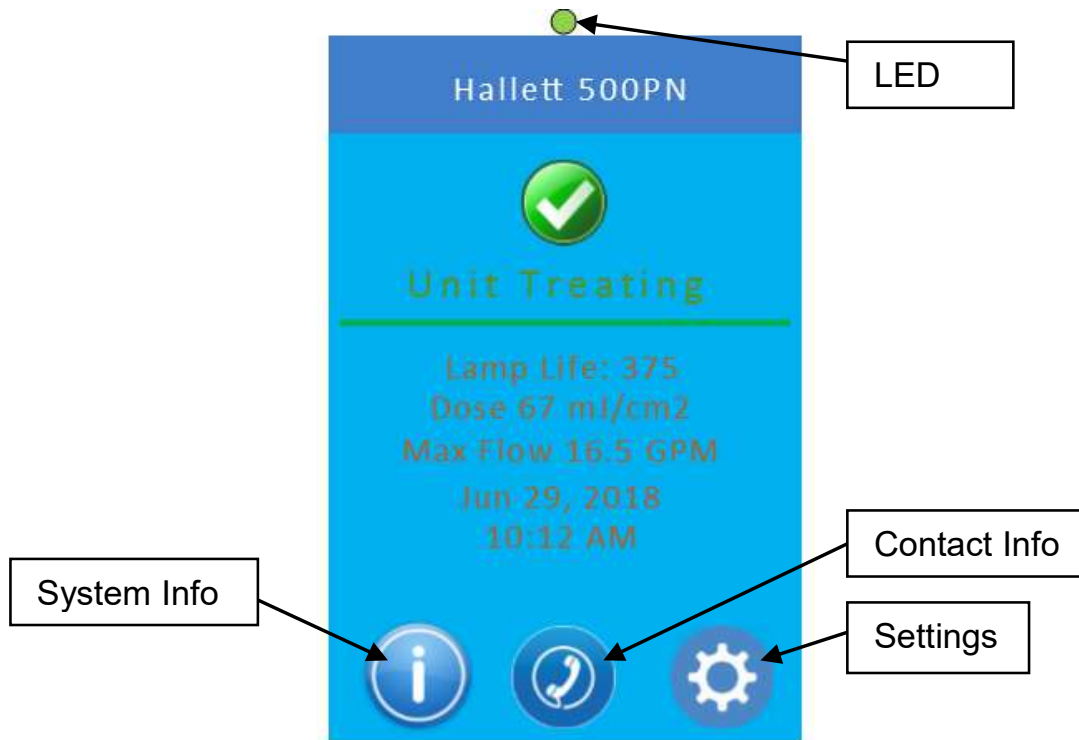

Figure 5.1

The user interface consists of a color touchscreen and a single multi-color LED. See Figure 5.1. The LED will always be illuminated when the UV unit is plugged in and powered up. The touchscreen enters sleep mode after 10 minutes and requires the user to touch it to wake it up. The touchscreen will change colors if any significant event occurs such as warnings or alarms. See the section on *Navigating the Menus* for a complete layout of the screens.

Indicating LED

Green Light – an illuminated green light indicates the unit is treating normally. A slow flashing green light means the UV lamps are not yet at full power or the unit is in standby mode awaiting a remote start. A fast flashing green light means the wiper is cycling.

Red Light – an illuminated red light indicates either a warning or an alarm has occurred. A warning is a condition that, if not addressed, could impact the unit's performance. Warnings should be addressed as soon as possible. Warnings are accompanied with a flashing red LED, a single beep, a message, and a yellow screen. An alarm is a condition that has significantly impacted the unit's performance and it must be addressed immediately. Alarms are accompanied with a solid red LED, continuous beeping, a message, and a red screen.

Audio Alarm

The audio alarm or beeper, will alert the operator to any conditions out of the ordinary. A single beep will sound if a warning occurs; continuous beeping will sound if an alarm occurs. The audio alarm may be disabled temporarily or permanently in the Settings Menu, item 2.3.

Navigating the Menus

0 Home

- 0.1 Model name
- 0.2 Treatment Status
- 0.3 Lamp Life
- 0.4 UV Dose
- 0.5 Max Flow or Flow Signal (Optional)
- 0.6 Date & Time

0A Contact Info

Text: Company, Phone, Installation date

1 System Info

- 1.1 UVT
- 1.2 UVI
- 1.3 Left Lamp UV
- 1.4 Left Water UV
- 1.5 Right Lamp UV (If available)
- 1.6 Right Water UV (If available)
- 1.7 PCB Temp
- 1.8 Sys Temp
- 1.9 Water Temp
- 1.10 Lamp Temp
- 1.11 Wiper Countdown
- 1.12 Daily Starts
- 1.13 Firmware Version
- 1.14 Total Starts
- 1.15 Power-ups
- 1.16 Life-time counter
- 1.17 CH1 - Analog Output
- 1.18 CH2 - Analog Output

- 2 Settings
 - 2.1 Date & Time
 - 2.2 Power Down
 - 2.3 Audible Alarm
 - 2.4 Units
 - 2.5 Reset Lamp Counter
 - 2.6 Message History (Last 100 messages)
 - 2.6.1 {Message 1}
 - 2.6.1.1 UV Dose
 - 2.6.1.2 Water Temp
 - 2.6.1.3 Estimated UVI
 - 2.6.1.4 Estimated UVT
 - 2.6.1.5 Left Lamp UV
 - 2.6.1.6 Left Water
 - 2.6.1.7 Right Lamp UV
 - 2.6.1.8 Right Water
 - 2.6.1.9 Lamp Temp
 - 2.6.2.0 PCB Temp
 - 2.6.2.1 System Temp
 - 2.6.2 {Message 2}
 - 2.6.3 ...

- 2.7 Advanced Settings
 - 2.7.1 Force Outputs
 - 2.7.1.1 Lamps
 - 2.7.1.2 Wiper
 - 2.7.1.3 Purge Valve
 - 2.7.1.4 Shutoff Valve
 - 2.7.1.5 Fan UV
 - 2.7.1.6 Fan PCB
 - 2.7.1.7 Warning Contact
 - 2.7.1.8 Run Contact
 - 2.7.1.9 Buzzer
 - 2.7.1.10 Heaters
 - 2.7.1.11 C1-4-20mA signal
 - 2.7.1.12 C2-4-20mA signal
 - 2.7.1.13 Interlock for UV door
 - 2.7.1.14 Wiper Positioner switch
 - 2.7.1.15 Remote Start/Stop Signal
 - 2.7.1.16 Fault 1
 - 2.7.1.17 Fault 2
 - 2.7.1.18 Lamp Temp
 - 2.7.1.19 Water Temp
 - 2.7.1.20 Analog In
 - 2.7.1.21 System Temp
 - 2.7.1.22 PCB Temp
 - 2.7.1.23 DC Volts
 - 2.7.1.24 L Lamp Sensor
 - 2.7.1.25 L Water Sensor
 - 2.7.1.26 R Lamp Sensor
 - 2.7.1.27 R Water Sensor
 - 2.7.1.28 CAL - L Lamp
 - 2.7.1.29 CAL - L Water
 - 2.7.1.30 CAL - R Lamp
 - 2.7.1.31 CAL - R Water
 - 2.7.2 Remote Start
 - 2.7.3 Shutoff Valve
 - 2.7.4 Set Defaults
 - 2.7.5 Language
- 2.8 Password for Advanced Menus

Starting the Unit

Plugging in the Hallett for the first time

Step 1: Ensure that all external wiring is complete (see *Control Interfaces* section) and all the panels of the unit are closed before connecting the power cord.

Step 2: Plug the female end of the power cord into the power entry module located on the left side of the front panel. Plug the male end of the power cord into a ground-fault circuit-interrupter (GFCI).

Step 3: Once the unit is plugged in, the LED illuminates, an audible tone is issued and the display becomes active to confirm all three devices are functional. The unit then performs a self-diagnostic. The user/installer should enter the date of installation in the Settings Menu, and treatment parameters if required.

Step 4: When the UV Lamps have started, (lamp ignition for amalgam lamps may take up to 30 seconds) the unit will wait at 10 - 15 minutes depending on the model to allow the lamps to stabilize before transitioning into Treating mode. This will occur every time the UV lamps are powered up. During this warm up, the green LED will flash, the unit will display the countdown to startup, and the optional shutoff valve will remain closed. **New LPHO lamps may take from a few moments to several hours to reach full power. Continue to operate the unit until the lamps reach full power – this may last 24 hours. It is recommended for new LPHO lamps to be operated initially 3-4 hours as a burn-in to achieve lamp stability.**

When the warm up process is complete, a solid green light appears and the message “Unit Treating” will be displayed. The optional solenoid valve will be allowed to open only if treatment levels are adequate, otherwise it will remain closed. This is the normal operating mode of the unit.

During normal operation if a power outage occurs, upon return of the power, the unit will start up automatically and perform a diagnostic check. After a 10-15 minute stabilization period, the unit will begin treating if treatment levels are adequate, otherwise an alarm will be issued if the unit is not treating.

Test the wiper motor and purge valve - see Advanced Settings menu, items 2.7.1.2 and 2.7.1.3.

Flushing Instructions

Flushing the system is required after installation or after any disassembly and cleaning. Flushing may also be required to remove colored or contaminated water from the unit. Most filters (if installed) also require flushing prior to use – follow the manufacturer's recommendations.

The system may be flushed in two ways. It can be done manually by disassembling the unit and filling and draining the unit by hand (see In-place Cleaning section). Flushing may also be done while the unit is operating. Plug in the unit and open a tap closest to the unit and have the water flow for a minimum of 15 minutes.

Shutting Down of Unit and Seasonal Use

To shut the unit down, initiate the Power Down procedure located as the second item in the Settings Menu. When this procedure is complete, simply unplug the unit.

The Hallett can operate for extended periods of time without water usage **as long as pressurized water is present to allow for purging**. The unit may be shutdown in the case of seasonal residences or during a vacation. If the possibility of freezing exists, the unit and any valves and filters must be drained. (See *Draining the Unit* section.)

Disinfecting the Plumbing

Disinfection of the household or facility plumbing should be performed after the Hallett has been installed and is operating. This procedure should also be done if the unit is not functioning normally; if a bypass has been used; or if there has been a high background bacteria count in a water sample. UV Pure has found that disinfecting the plumbing will ensure that any potential bacteria or contaminants in the distribution system are treated prior to system use.

Please note that this procedure is ineffective against protozoa that can be found in surface water or shallow wells under the influence of surface water. Under these circumstances, it is important to perform the disinfecting procedure and then operate the Hallett. UV Pure has found that this procedure does not work with sediments or heavy biofilm and encrustations, which must be removed mechanically.

UV Pure recommends sanitizing the household or facility plumbing by adding 50 ppm chlorine from bleach for 12 hours and then flushing. This can be achieved by doing the following:

Plumbing disinfection procedure

Step 1: Shutdown and unplug the unit.

Step 2: Shut off the water supply and relieve the water pressure by opening a tap.

Step 3: Remove the filter from its housing and fill the housing with bleach

Step 4: Re-mount the housing (but not the filter) and plug in the unit to turn it on.

Step 5: Once the unit is operating, turn on the water supply and have the water flow to all taps (hot and cold), toilets, the washing machine and other water-using appliances – the bleach must fill every inch of plumbing. The Dose Alarm may arise due to low UVT after the introduction of bleach. If this occurs, use the manual override on the optional solenoid valve to keep valve open during procedure. **Return override to auto position afterward.**

Step 6: When you detect the odor of chlorine at each spot, turn off the water and let the bleach remain in the lines for at least 12 hours and **turn off** the UV unit during this time.

Step 7: After the waiting period is over, plug in the unit. Once stable, flush every line for at least five minutes or until the odor of chlorine is gone. See local regulations for proper disposal of chlorine residual, especially in the case of discharge into a septic system.

Step 8: Now that the disinfection procedure is complete you will need to return the filter to its housing. Shut off the water supply, relieve water pressure by opening a tap, and return the filter to the housing. Allow a few days after a disinfection procedure before getting a sample since residual chlorine may affect the results.

Have the water tested by a local recognized testing agency prior to any water consumption.

Automatic Quartz Sleeve Cleaning Device (available on most models)

The self-cleaning feature of the Hallett system involves a wiper turning inside the quartz sleeve. The wiper operates soon after power up of the lamps and then every 4 hours it will cycle for 5 minutes. The wiper can be enabled anytime in the Advanced Settings menu, item 2.2.1.2. The LED will flash quickly during the wiper cycle

Built in Purge Valve (available on most models)

The Hallett contains a flushing or purge valve that cycles water through the unit during long periods of no water usage. The unit monitors water usage by measuring the rise in water temperature within the treatment chamber. During periods of no water flow, the purge valve on the small units can expel 1 gallon (4 liters) of water every 60-90 minutes; the largest unit can expel up to 3 gallons (12 liters). If the largest unit fails to purge and the water temperature exceeds 122°F (50°C), the unit will shutdown to prevent overheating.

TROUBLESHOOTING

The Hallett will operate unattended until a fault arises.

If an **alarm** occurs, the solenoid valve (optional) will close, preventing water from flowing; the LED turns red; the audio alarm will beep continuously; the touchscreen turns red and displays a message; the RUN contact will open to indicate the unit is no longer treating. The fault should be corrected to return the unit to normal operation and have the water flow again.

If a **warning** occurs, the solenoid valve (optional) remains open; the LED flashes red; the audio alarm will beep once; the screen turns yellow and displays a message; the warning contact will close to indicate the unit is still treating but in an abnormal state. The warning should be addressed as soon as possible and if left unattended, could turn into an alarm.

The Message History, available in the Settings menu, item 2.6, is very useful in troubleshooting since it contains up to 100 messages/events with associated recorded data such as times, UVI, UVT, UV sensor values, and temperatures.

In the event of an alarm, in many cases, a physical inspection of the unit with the power off should be done to try to identify a cause. A slow water leak for instance, near the top of the unit could stain lamps or reflectors and may not be uncovered without a full system inspection.

Dose Alarm

The Dose Alarm occurs when there is insufficient UV dose to treat the maximum flow rate prescribed by the unit. The Dose Alarm could be a result of low UV intensity or low UV Transmittance (UVT) or a combination of both. Review both values in the System Info Menu to determine which is causing the alarm and take corrective action. It is highly recommended to have a UVT sample taken to confirm system prediction.

The Advanced Settings menu under Force Outputs conveniently provides the ability to manually turn on and off devices to confirm their operation. Devices return back to their automatic position after 10 minutes.

Cycling the power is also useful to occasionally reset the software.

Troubleshooting Guide

System Status	Possible Cause	Corrective Action
No Power (LED is off, touchscreen is off)	Ground-fault circuit-interrupter (GFCI) tripped.	Check for water leaks. Reset GFCI.
	Fuse Blown.	Check for water leaks. Replace fuse (see Fig. 4.4 for fuse location)
	Touchscreen pcb not connected to power pcb.	Ensure ribbon cable is connected at both ends.
	Circuit Board is damaged.	Confirm if Power pcb has any illuminated LEDs. If so replace Touchscreen pcb (LCD).
UV Lamps not starting (occurs after 6 unsuccessful attempts)	UV Chamber interlock not engaged.	Check that each latch is correctly positioned and secure UV chamber door.
	# of lamp starts have exceeded specification.	Review Total Lamp starts in System Info Menu. Replace lamps but reduce future lamp cycles.
	UV lamp failure	Replace lamps
	UV Ballast Failure	Replace ballast
	Over temperature condition.	Either the system, pcb or water temperature has occurred. Allow to cool off and investigate cause by reviewing Message History.
UV Lamps on but UVI is low	Lamps are warming up after a power interruption.	Allow lamps up to 15 minutes to reach full power
	New LPHO lamps installed.	First time LPHO lamps are turned on it may take 3 to 4 hours to reach full power. After this initial "burn-in", warmup time will be a few minutes.
	The UV output of the lamps have diminished.	Lamps have exceeded their lifetime. Replace lamps. # of lamp starts have exceeded specification. Replace lamps but reduce future lamp cycles.
	UV sensor requires recalibration/replacement.	Install reference sensor to confirm status of unit sensor.
	UV Lamps operating outside of recommended temperature conditions.	Check if UV blower is operating correctly. For cold water applications, increase room temperature or install LPHO lamp heater kit.
Water Temperature High Warning & Alarm	Warning issued when water temperature within the UV chamber exceeds 104°F (40°C).	Check if sufficient water pressure to operate purge valve. Check for blockage in purge discharge tubing.
	Alarm issued when water temperature within the UV chamber exceeds 122°F (50°C) – UV Lamps are turned off (applies to Hallett 1000 models)	Check for debris in purge valve.
System Temperature High Warning & Alarm	The system temperature has exceeded a safe operating level causing the UV lamps to be turned off.	Check if water flow has been turned off. Check if operating temperatures have exceeded specifications. Check if both system blowers are operating correctly.
Circuit Board Temperature High Alarm	The temperature within the electrical chamber has exceeded a safe operating level causing the UV lamps to be turned off.	Check if operating temperatures have exceeded specifications. Check if the pcb blower is operating.
Wiper Not Turning Warning	The system has failed to detect wiper motion during the routine wiper cycle.	Check wiper motor operation
		Check wiper position switch & cam.
		The UVT is too low for detection. The Wiper Position Switch option is recommended.

7. MAINTENANCE

The disinfection of water will occur as long as the unit is properly maintained with genuine parts in accordance with the instructions set out in this manual. Operating a malfunctioning unit or defeating any system sensors may jeopardize the safety of the water. Online videos are available to help with typical maintenance tasks.

Test Shutoff Valve Monthly

The optional solenoid shutoff valve should be tested monthly to confirm it opens and closes. Unplug valve from unit to confirm water stops flowing. Plug the valve in again to confirm water continues to flow.

Clean Air Filter Periodically

The Hallett contain a washable air filter in the located at the air inlet port (See Figure 7.1). Periodically check and clean the filter to ensure blower operation is not impeded.

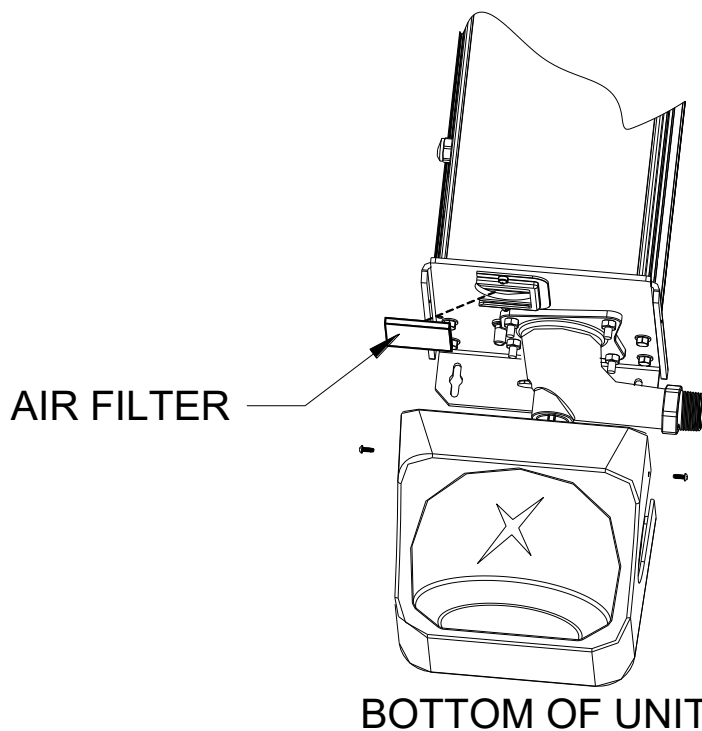

Figure 7.1

Accessing the UV Chamber

The UV chamber can easily be opened for lamp replacement or quartz sleeve inspection without having to drain the unit and without any tools.

Caution: Always shutdown and unplug the unit before accessing the UV Chamber

Step 1: Shutdown and unplug the unit then wait 5 minutes before opening the UV chamber to allow the lamps to cool. The lamps heat up after continuous use and can burn your skin if touched.

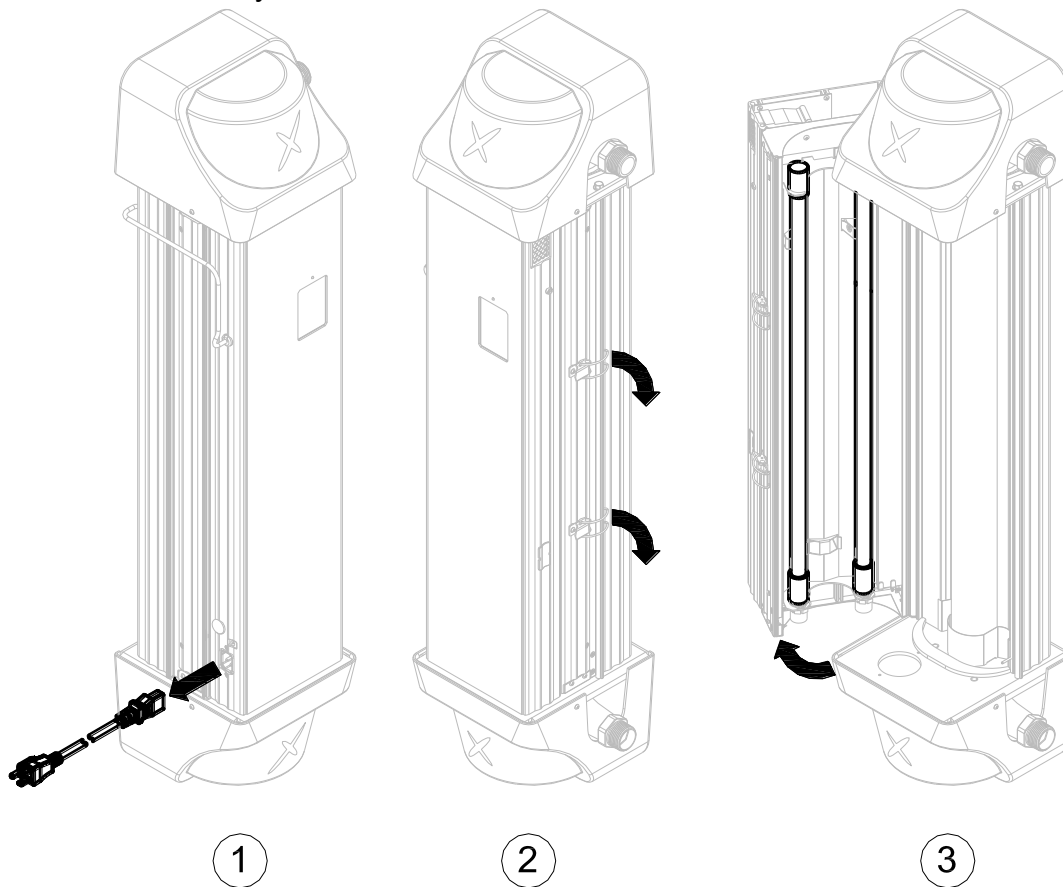

Figure 7.2

Step 2: See Figure 7.2. Open the UV Chamber by undoing the over-the-center latch (may be more than 1). Note where the latch wire engages the extrusion feature – it must be re-latched in same manner.

Step 3: Slowly swing the door completely to the left to reveal the two UV lamps installed in the front half of the UV chamber. Note that the quartz sleeve can be easily inspected.

Step 4: To close the UV chamber, slowly swing the door back towards the back half of the UV chamber. Close all over-the-center latches ensuring the wire correctly grabs the extrusion feature.

Step 5: Plug the unit in again.

Replacing and Cleaning UV Lamps

The Hallett contains two ultraviolet (UV) lamps that emit high-intensity UV light in the germicidal range, providing effective disinfection of the water flowing through the unit. The lamps in the unit will decay over time and they

should be replaced every 12 or 16 months for optimum performance – see Product Specification Tables for lamp lifetimes. Note that lamps will only decay while in operation. Shutting down the system for seasonal use will extend lamp life.

The unit has an internal timer to keep track of the lifetime of the lamps. The Hallett will issue a warning when the end of lamp lifetime approaches and it will warn again when the lamp lifetime is exceeded. The amount of life remaining on the lamps is measured in days and can be seen in the Home menu.

The lamps can be replaced in a few minutes. See figures 7.3-7.5

NOTE: Resetting the Lamp Lifetime counter will clear the Message History, Lamp Starts counter and Power Ups counter. If this information is required, review it first before proceeding to Step 1.

Step 1: Open the UV chamber as described in *Accessing UV Chamber* section.

Step 2: Use a slotted screwdriver and pry the lamps up between lamp base and ceramic socket.

When the bottom pins have disengaged the socket, lift the lamp up, then swing the lamp base away from socket. Lower the lamp to disengage it from the top lamp holder. With the lamp free from the unit, carefully place it aside and remove the other lamp.

Dispose of the old lamps in the same way as you would dispose of ordinary fluorescent tubes. Note that old lamps should be disposed of at a household waste management depot or transfer station; contact your local recycling and waste management authority for proper disposal procedures in your area.

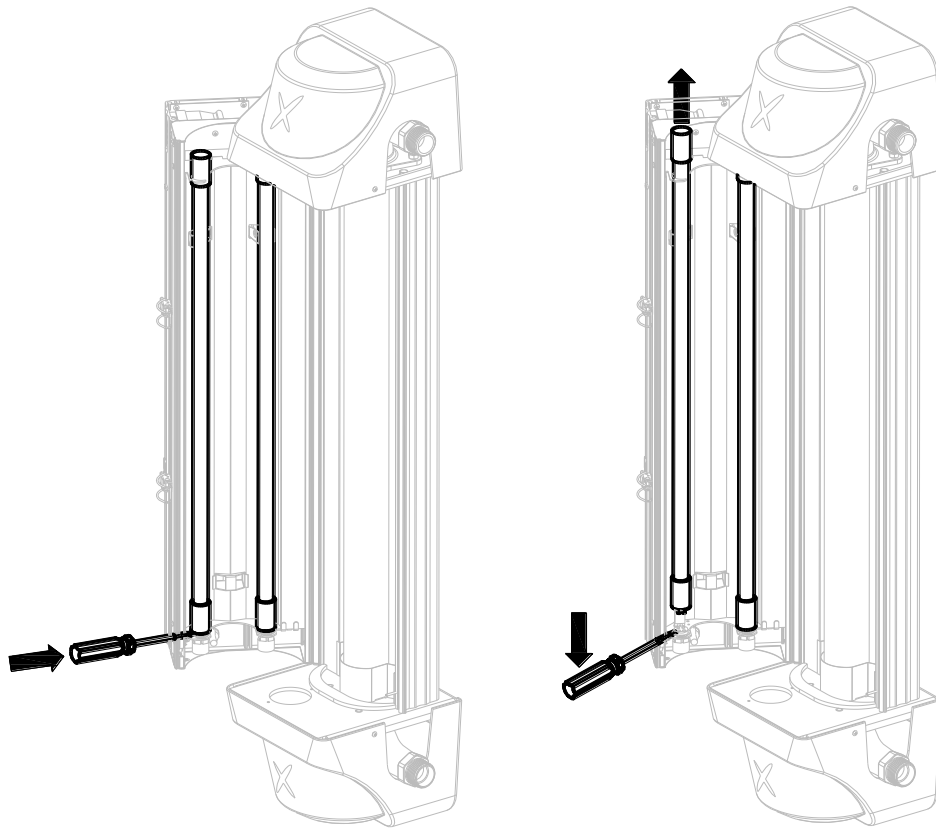

Figure 7.3

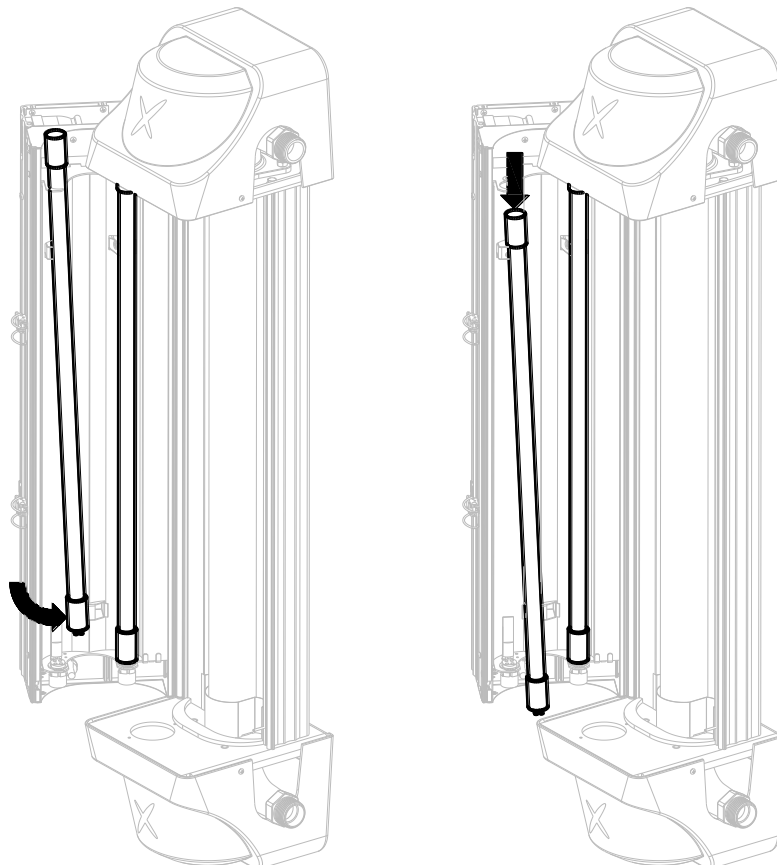

Figure 7.4

Step 3: Install the new lamps into the unit, one at a time being careful not to touch the bulb. Insert the top end of the lamp through the top lamp holder then swing lamp base in over the socket. For a LPHO lamp, rotate it until the “Stop Sign” symbol printed on the top ceramic is towards the left. See Figure 7.5. For an amalgam lamp, rotate it until the wires running down the lamp are facing the back of the unit. The proper orientation of the LPHO and amalgam lamp has the lamp wires opposite the UV sensors.

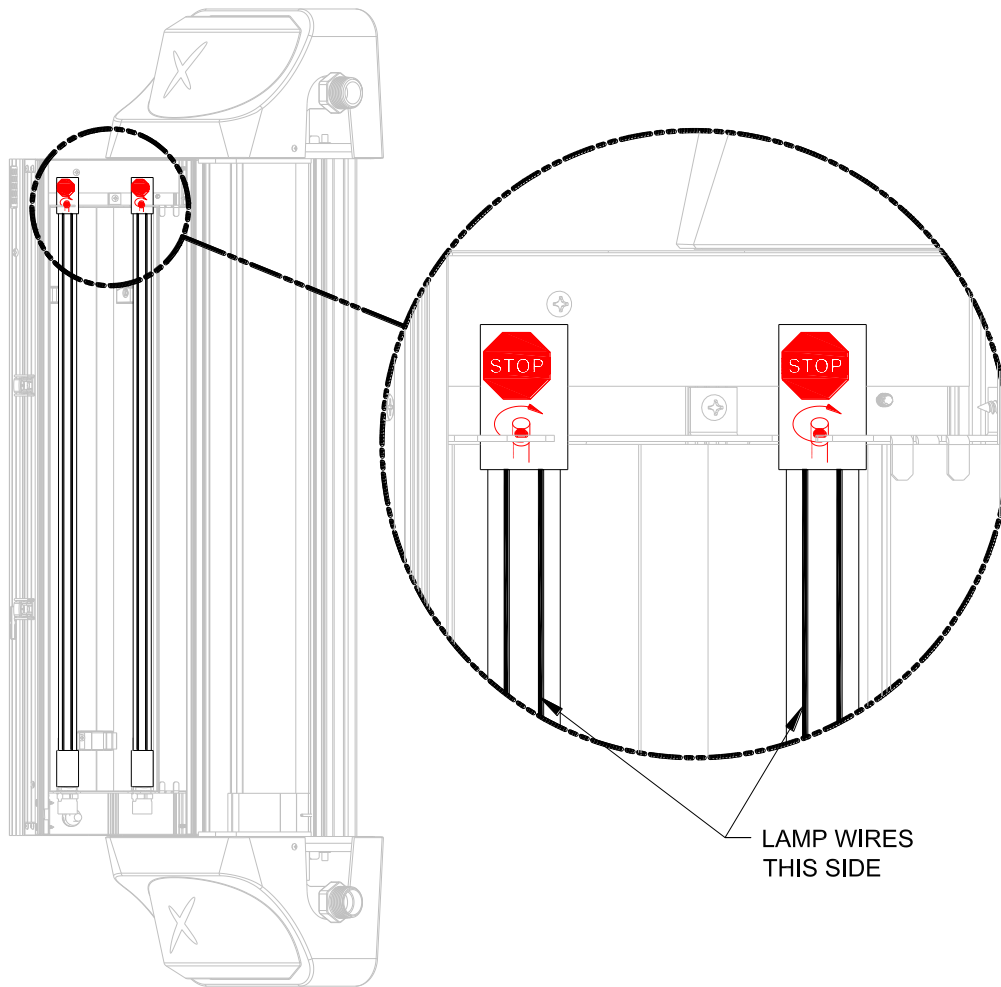

Figure 7.5

After the lamp has been rotated correctly, allow the 4 pins of the lamp to engage into the socket, push firmly down on the top of the lamp. **Do not twist the lamps when they are inserted.** Observe the base of the lamp to confirm the pins are fully seated into the socket. Repeat for other lamp.

Step 4: Close the UV Chamber and secure door.

Step 5: Record the date of the lamp replacement in your Service Record Sheet.

Step 6: Plug in the unit. The lamp lifetime counter can be reset in the Settings menu, item 2.5 (365 days for LPHO lamps, 500 days for amalgam lamps). **New LPHO lamps may take from a few moments to several hours**

to reach full power. Continue to operate the unit until the lamps reach full power. The UV intensity value can be observed to confirm output levels. It is recommended for new LPHO lamps to be operated initially 3-4 hours as a burn-in to achieve lamp stability.

Draining the Unit

The Hallett does not normally require draining for routine operation or lamp replacement. Draining is necessary to disassemble the system, to protect against freezing, or to remove poor-quality water.

Step 1: Shut off the water supply and relieve the pressure.

Step 2: Shutdown and unplug the unit.

Step 3: Place a bucket under the unit to collect the water.

Step 4: Open a tap downstream of the unit to vent.

Step 5: If you have installed an optional drain valve, open the drain valve. If you do not have an optional drain valve, disconnect the flexible hose or piping at the bottom port to allow the system to drain for a few minutes. Note that the water will not flow backwards through the optional automatic valve.

Step 6: When draining is complete, close the drain valve or reconnect the flexible hose or pipe connections.

Step 7: Close any taps that were previously opened.

Cleaning the Unit

UV Pure has designed the automatic quartz sleeve cleaning device within the Hallett systems to virtually eliminate the disassembly and cleaning of the quartz sleeve - the quartz sleeve will remain clear and transparent as glass. If a component of the cleaning device fails, such as the wiper motor, or in extreme water cases with unique water chemistry, the quartz sleeve may become fouled and require manual cleaning. In this situation the Dose Alarm will arise and alert you to the unsatisfactory conditions. Follow the steps below to inspect the quartz sleeve and disassemble the unit for cleaning.

Determining the Need for Cleaning

Step 1: Shutdown and unplug the unit.

Step 2: Open the UV chamber as described in *Accessing UV Chamber* section.

Step 3: Examine the quartz sleeve both inside and out – See Figure 7.2. If it

is clean, no disassembly is required and the unit can be closed. Restart the unit by plugging it in.

Step 4: If the quartz sleeve is dirty on the outside, proceed to wipe it down with a clean lint-free cloth and rubbing alcohol to remove the dirt. If the quartz sleeve is dirty on the inside, proceed with in-place cleaning or disassembly.

In-place cleaning

This procedure will clean the quartz sleeve without its removal from the unit. This is a quick and easy procedure that works well in most cases.

Step 1: Fill a bucket or container with 1 gallon (4 liters) of clean water - this will be required later to clean the quartz sleeve. A squeeze bottle is useful for applying water or cleaning solution to the inside of the quartz sleeve.

Step 2: Shutdown and unplug the unit.

Step 3: Shut off the water supply and relieve the pressure.

Step 4: Open the UV Chamber as described in *Accessing UV Chamber* section.

Step 5: Place another bucket under the unit and drain the unit until there is about 1" (3cm) of water left in the quartz sleeve (see *Draining the Unit* section).

Step 6: Disconnect the fitting at the top outlet port of the UV unit. If the stainless flexible hose was installed, disconnect the hose opposite from the UV unit then bend the open end upwards – this will make the next step easier.

Step 7: Add about 2 oz. (60cc) of cleaning solution to the top hose/manifold. The cleaning solution can be a citric acid, vinegar or other non-hazardous solutions. **Any solution used should be thoroughly rinsed out afterwards.** Fill the rest of the quartz sleeve with water.

Step 8: Let the cleaning solution remain in the quartz sleeve for at least 10-20 minutes.

Step 9: Manually turning the wiper may greatly assist the cleaning process. To do this, remove the top plastic cover then remove the motor and turn the wiper shaft with a slotted screwdriver (counterclockwise while looking at the shaft). If the optional wiper positioner switch is installed, leave the trigger cam in place.

Step 10: Drain the unit and inspect the quartz sleeve. If clean, flush the unit with clean water. If fouling remains, repeat procedure or proceed to disassembling the unit.

Step 9: Once the unit is clean, reassemble the system including the motor, plastic cover, top port connection(s) and UV chamber door.

Step 10: Slowly open the water supply and check for leaks.

Step 11: Restart the unit by plugging it in.

Step 1: Fill a bucket or container with 1 gallon (4 liters) of clean water - this will be required later to clean the quartz sleeve. A squeeze bottle is useful for applying water or cleaning solution to the inside of the quartz sleeve.

Step 2: Shutdown and unplug the unit.

Step 3: Shut off the water supply and relieve the pressure.

Step 4: Place another bucket under the unit and drain the unit completely (see *Draining the Unit* section). Note that piping connections to the inlet and outlet ports will have to be removed in order to disassemble the unit's stainless manifolds. Perform these disconnections now.

Step 5: Open the UV Chamber as described in *Accessing UV Chamber* section. It may be necessary to have the UV chamber door held open for this procedure.

Step 6: Remove top plastic cover.

Step 7: Disconnect wires to wiper motor, purge valve, and water temperature sensor (thermistor).

Step 8: Remove the wiper motor by removing the two screws holding it to the plate.

Step 9: Remove the motor mounting plate from the top manifold by removing the two screws and nuts. Removing this plate will allow top manifold to come free from the wire bundle

Caution: Do not damage the sealing surfaces of the manifolds or the shaft adapter for the wiper - handle these parts with care to prevent water leaks. The wiper assembly must also be handled with care to prevent damage to cleaning edges. **The wiper blades are sharp, handle them with care.**

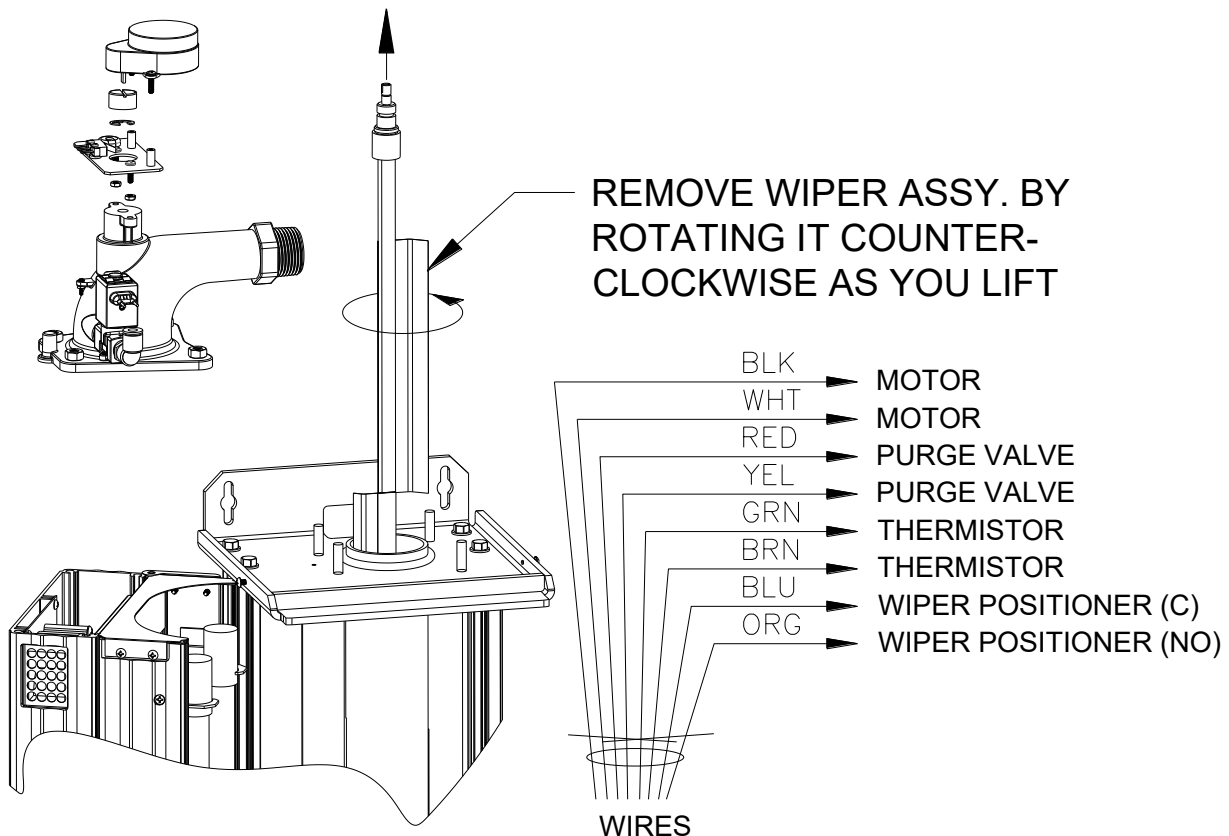

Figure 7.6

Step 10: Remove the retaining ring (E-ring) holding the wiper shaft.

Step 11: Use the 7/16" (11mm) wrench or nut driver to remove the four nuts of the top manifold in an alternating pattern (top left, bottom right, bottom left, then top right). The bottom manifold does not require removal to clean the quartz sleeve, so leave it in place. This will support the quartz sleeve during cleaning and simplify the overall process.

Step 12: Press down on the wiper shaft and remove the top manifold (Figure 7.6) by lifting it straight up to disengage the wiper shaft. The shaft adapter should remain on the top of the wiper shaft. Note the orientation of the slot to the wiper blades – the slot is aligned to the wiper blades.

Step 13: Remove the wiper assembly by carefully lifting it up and out of the quartz sleeve. Rotating it counter-clockwise as you lift will help. Prevent the shaft adapter from falling off the wiper assembly. Note that the shaft adapter sits on the top end of the wiper shaft - the top end of the shaft has a hole, the bottom end of the shaft does not.

Cleaning/Removing the Quartz Sleeve

Step 1: Use a bottle cleaning brush with a long handle to scrub the inside of the quartz sleeve. Scrub and flush it with water repeatedly to clean the quartz sleeve. Use a squeeze bottle to apply water or solution to the quartz sleeve to keep the area tidy. **Note: Keep the rest of the unit free from moisture.** Examine the quartz sleeve.

Step 2: If the quartz sleeve is still dirty, use a scale remover such as CLR or Lime Away and apply it to the inside of the quartz sleeve. Citric acid, available at a drug store, can also be used. **Always flush with clean water afterwards.**

Step 3: Once the quartz sleeve is clean, reassemble the unit (see Figure 7.8). Replace any seals that appear to have been damaged.

Step 4: If the quartz sleeve is still not clean, it requires replacement. This is done by removing the bottom manifold (see Figure 7.7). Replacing a quartz sleeve is easier when the unit is placed on a horizontal surface – removing the unit from the wall to work on a bench is recommended, especially for the Hallett 1000 models.

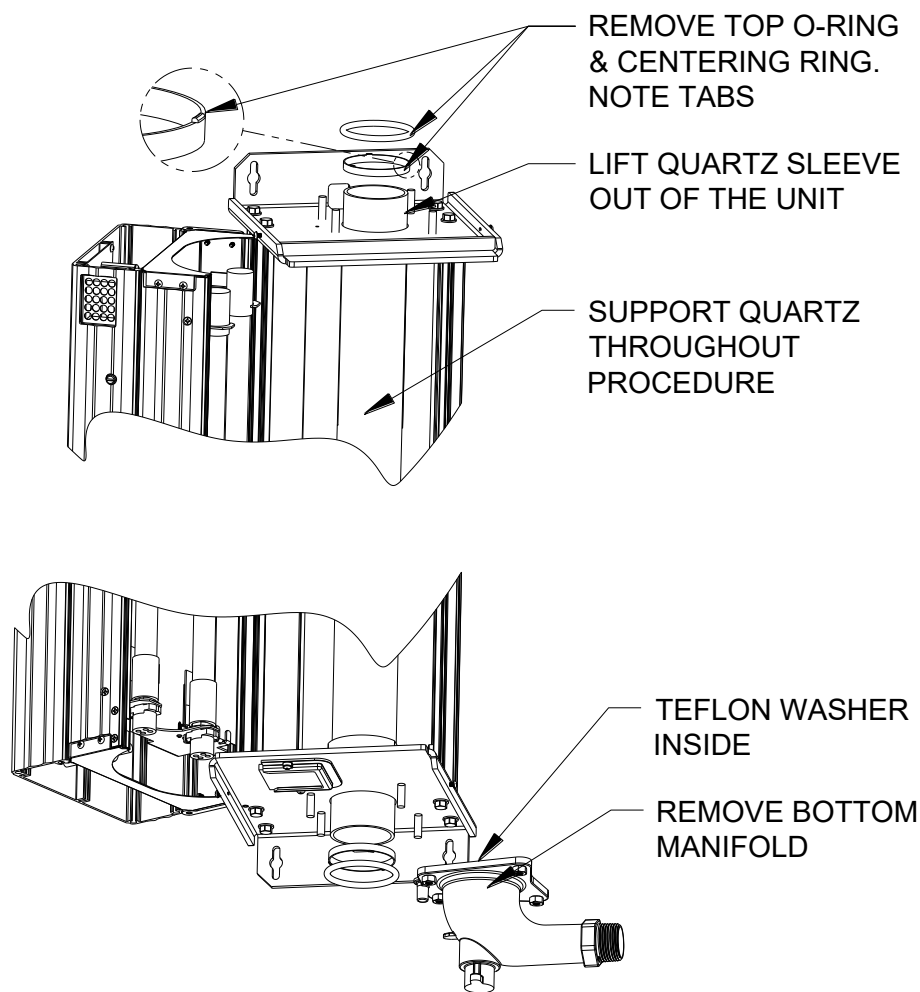



Figure 7.7

Step 5: Remove the bottom plastic cover and then the bottom manifold by undoing the four nuts in an alternating pattern (top left, bottom right, bottom left, then top right). Do not allow the Teflon washer at the lower cavity of the bottom manifold to fall out – the wiper shaft sits on this washer. Support the quartz sleeve as you remove this item.

Step 6: Remove the quartz sleeve by removing the top and bottom O rings and then the quartz centering rings. Lift the quartz sleeve out of the unit.

 **Step 7:** Install the new quartz sleeve into the unit and center it vertically. **Be careful not to chip the ends.** Support the quartz sleeve for the next two actions.

Step 8: Install the quartz centering rings (small tabs face outwards) and then the top and bottom O rings, keeping the quartz sleeve centered vertically in the unit.

Step 9: Replace the bottom manifold (see Fig. 7.7) by installing the four nuts in an alternating pattern (top left, bottom right, bottom left, then top right). Check again for Teflon washer.

Reassembling the Unit

Step 1: Replace the wiper assembly carefully in the quartz sleeve -wetting the inside of the quartz sleeve with water will also make the task easier. Turn the wiper assembly counter-clockwise (looking from the top) as it is being inserted into the quartz sleeve – this will make the task easier and align the wiper blades properly. Ensure the bottom of the wiper is correctly seated into bottom manifold.

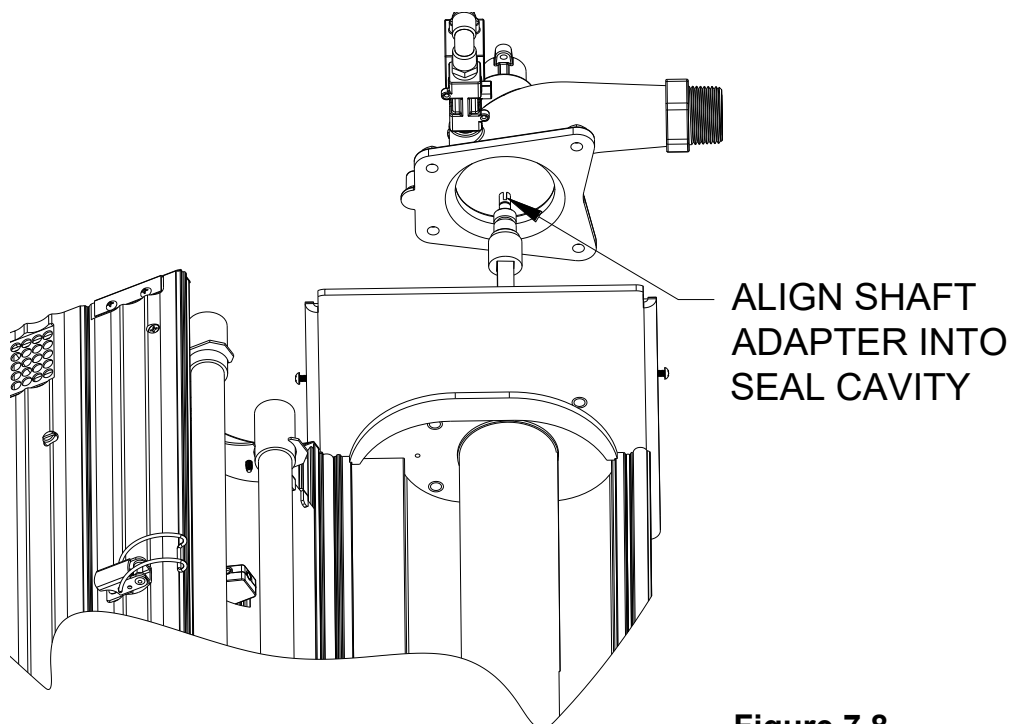

Figure 7.8

Step 2: Ensure the quartz O-ring seal is in place around the quartz sleeve and then replace the top manifold by aligning the shaft adapter into the seal cavity of the top manifold (see Figure 7.8).

Step 3: Tighten the nuts in an alternating pattern. Once top manifold is secure, replace the retaining ring on the wiper shaft. Rotate the wiper assembly CCW to have the top wiper blade facing the back of the unit.

Step 4: Reconnect both top and bottom piping connections. Close the UV Chamber door.

Step 5: Close any taps and slowly open the water supply. Inspect for leaks. Repair any leaks if necessary before plugging in the unit.

Step 6: Reinstall the motor mounting plate by using the trigger cam to center the plate (center hole to be concentric with wiper shaft). With the top wiper blade facing the back, the trigger cam should have the dimple in the 10 o'clock position. Install the wiper motor, then reconnect all the wires.

Step 7: Reinstall the top and bottom plastic covers.

Step 8: Plug in the unit. Check operation of wiper motor, purge valve and water temperature switch.

Step 9: Make an entry in the service record to establish a cleaning schedule.

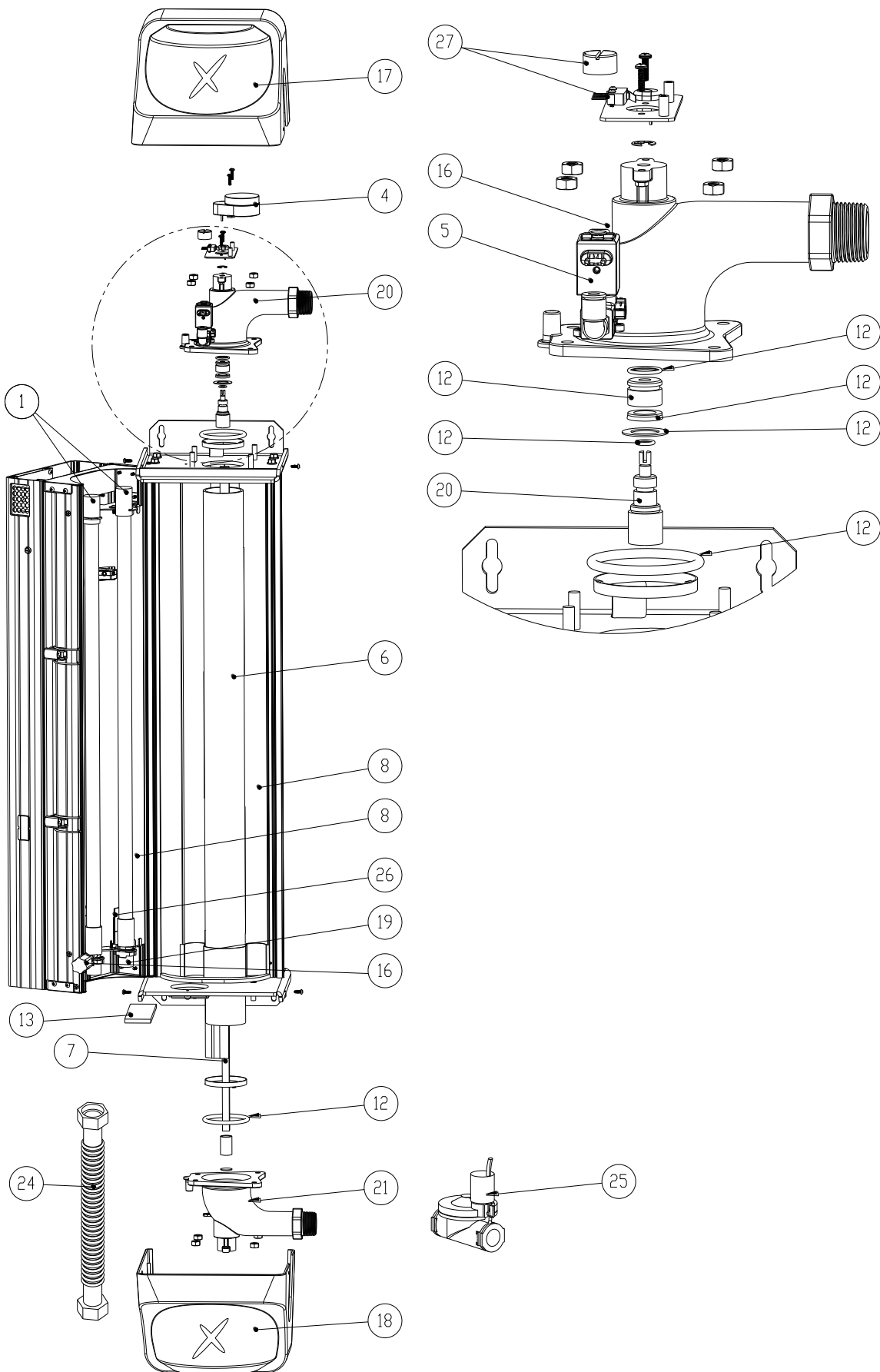
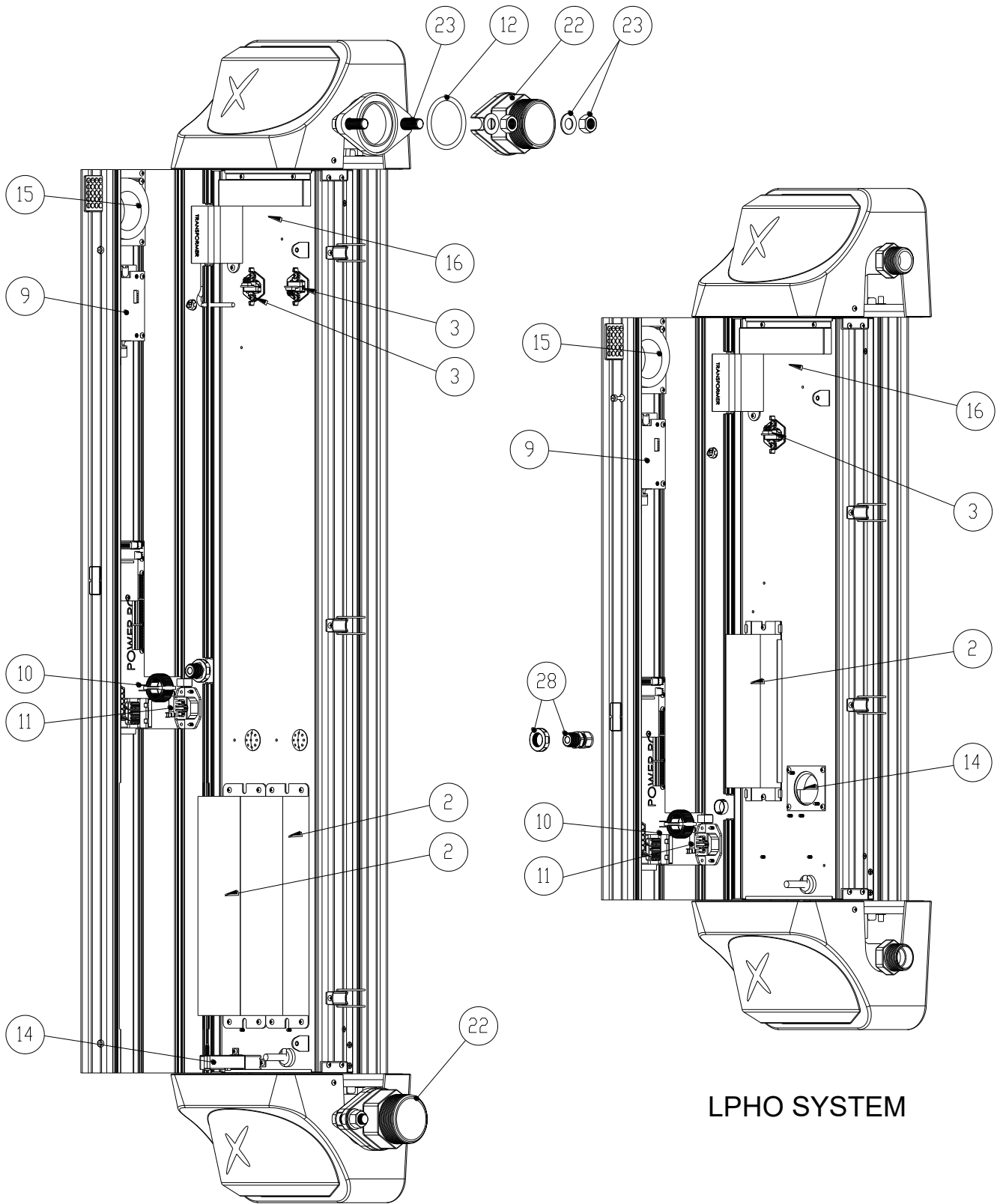

Figure 7.9A



AMALGAM SYSTEM

LPHO SYSTEM

Figure 7.9B

Hallett Spare Parts List

Item No.	Part Name	Model			
		Hallett 1000XX	Hallett 750XX	Hallett 500XX	Hallett 400XX
1	UV Lamps (Shipped in pairs)	GC19			
			C300065 (single lamp p/n is C300064)		
				E300210 (single lamp p/n is E300209)	
					E300165
2	Electronic Ballast	GA35 (2 per unit)	GA29 (1 per unit)		
3	UV Sensor Kit	GD1 (some units have 2 - see Product Spec. Table)			
4	Wiper Motor Kit	R400005			
5	Purge Valve Kit	H400000			
6	Quartz Sleeve Replacement Kit (includes 2 O rings)	GDQ-XL	GDQ-L	GDQ-M	GDQ-S
7	Wiper Assembly Kit	GDW-XL	GDW-L	GDW-M	GDW-S
8	Reflector Kit (shipped & sold in pairs)	GDR-XL	GDR-L	GDR-M	GDR-S
9	Circuit Board - LCD	Contact UV Pure			
10	Circuit Board – Power (120V Systems)	GD3			
11	Fuse Pack (5 pcs)	GD4 (for 120Vac systems, fuse is 6A, 250V 3AG)			
12	Seal Kit (complete)	GD5 (2" Port)	GD6 (1" port)		
13	Air Filter	GD7			
14	UV Chamber Blower Kit	GD8			
15	Circuit Board Blower Kit	GD9			
16	Temperature Sensor (Thermistor) Kit	GD10 (3 per unit)			
17	Top Plastic Cap	GD11			
18	Bottom Plastic Cap	GD12			
19	Lamp Socket Wire Harness	GA12 (2 per unit)	GA13 (1 per unit)		
20	Top SS Manifold/ Thermistor/Purge Valve Kit	GD13 (2 inch)	GD14 (1 inch)		
21	Bottom SS Manifold	GD15 (2 inch)	GD16 (1 inch)		
22	2" NPT Adapter (1 pc.)	GC25			
23	Fastener Kit for 2" Adapter (2 per unit)	GD22			
24	Optional Flexible SS Hose	GD17 (2" hose)	R400007 (1" hose)		
25	Optional Solenoid shut-off Valve – Nylon	550213	E500021 (1" ports)		
	Optional Solenoid shut-off Valve – Brass		550195 (1"ports)		
26	Optional Heaters for LPHO Lamps		GD18		
27	Optional Wiper Position Switch Kit	GD19			

Product Line Feature Comparison

Feature	Hallett 1 st Generation	Hallett Upstream 2 nd Generation	Hallett 3 rd Generation	Hallett 3 rd Generation	Hallett 3 rd Generation
	H30, H13	H15xs, NC series	H400 series	H500, H750 series	H1000 series
Crossfire Technology®	Built in	Built in	Built in	Built in	Built in
>> Elliptical Reflectors, >> 360° Disinfection	Built in	Built in	Built in	Built in	Built in
>> Dual Lamps, >> Multiple Sensors	Built in	Built in	Built in	Built in	Built in
>> Self cleaning mechanism	Built in	Built in	-	Built in	Built in
User Interface	LED/1 button	LCD/LED 4 buttons	Touch screen Color	Touch screen Color	Touch screen Color
Operational alarms	Dual visual - audible	Dual visual - audible	Dual visual - audible	Dual visual - audible	Dual visual - audible
Display - Liquid Crystal (LCD)	Optional	Built in	Touch screen Color	Touch screen Color	Touch screen Color
Communications	4-20 mA output	NA	NA	4-20 mA output Modbus	4-20 mA output Modbus
Dry Contact (s)	Built in	Built in	1. Run/Treating 2. Warning	1. Run/Treating 2. Warning	1. Run/Treating 2. Warning
Remote Start/Stop	NA	Built in	Built in	Built in	Built in
Surge Protection	Optional	Optional	Built in	Built in	Built in
Message History	NA	Last 50 messages	Last 99 messages	Last 99 messages	Last 99 messages
Data logging - local	NA	NA	Optional	Optional	Optional
Flow range (@ 40 mJ/cm ² , 95% UVT)	up to 40 USgpm 151 L/min	up to 40 USgpm 151 L/min	up to 21 USgpm 79 L/min	up to 40 USgpm 151 L/min	up to 100 USgpm 378 L/min
Minimum UVT required	45%	50%	50%	50%	35%
Lamp Type	LPHO	LPHO	LPHO	LPHO	Amalgam
Lamp Expected Life	9000 hours	9000 hours	9000 hours	9000 hours	12000 hours
Lamp Heaters	NA	NA	Available	Available	NA
Time Needed for Lamp Change	5 minutes	< 5 minutes	< 2 minutes	< 2 minutes	< 2 minutes
Sensor Design	Analog technology	Digital technology	Digital technology NIST compliant	Digital technology NIST compliant	Digital technology NIST compliant
Dual Sensors	One per unit	One per unit	One per unit	One per unit	One per lamp 2 per unit
Temperature Control	Convection cooling Optional purge valve	Forced air cooling Built-in purge valve	Improved forced air cooling Built-in purge valve	Improved forced air cooling Built-in purge valve	Improved forced air cooling Built-in purge valve
Performance Validation	Factory Tested	Factory Tested	Factory Tested	Third Party Validation (1)	Third Party Validated
Drinking Water Performance Certification	NSF/ANSI 55 Class A	NSF/ANSI 55 Class A	Factory Tested	NSF/ANSI 55 Class A	US EPA UVDGM Validation
Drinking Water System Components – Health Effects / Lead Free Compliance	NSF/ANSI 61 certified	NSF/ANSI 61 certified	-	NSF/ANSI 61 & 372 certified	NSF/ANSI 61 & 372 certified
Drinking Water and Wastewater Reuse Performance Validation	Factory Tested	Factory Tested	Factory Tested	Factory Tested	NWRI Validation

(1) Pending

(2) NA - Not available



www.whiteint.com.au

www.whiteint.co.nz

Please always refer to our website for further technical information & new product innovations

Disclaimer: Every effort has been made to publish the correct information in this manual.
No responsibility will be taken for errors, omissions or changes in product specifications.

© 2024 Copyright White International Pty Ltd

TM ® - **WARNING:** Please be aware that various brands & products depicted within this document are subject to trademark, patent or design registrations. Infringement of any intellectual property contained within this document without express written authority by the appropriate intellectual property holder may result in further legal action to be taken. For any queries regarding use of the contained information please feel free to contact White International Pty Ltd.